

TNS010i TCP/IP Stack Chip

PRELIMINARY

Data Sheet and User Manual

Rev. 010-04-10-2011

Firmware 4.07

Checkout:

<http://www.tcpipchip.com>

for details and updates

TNS010i TCP/IP stack Chip



Description

TNS010i TCP/IP stack chip is a complete single turnkey product that enables the Internet connection. Not only does it reduce development time to market, the TNS010i allows several real-time efficient transmissions of data and commands between an 8/16/32-bit micro controller (MCU) and the core TCP/IP software engine. With no priori information about the Internet protocol or networking, this device allows the MCU to send and receive web pages, data, and commands in a form of scripting phrases through its built in TCP/IP protocol engine.

Executing only a few simple commands from an MCU through serial pins of TNS010i and you will be able to transmit and receive data to/from web application program. Each command sent across the TNS010i will invoke TNS010i to response back to an MCU with a message. This debugging information helps users keep track of every step during the connection attempt.

This device can connect to the GPRS phone directly with no additional components. Even the MCU needs to set-up or read out the GPRS parameters, this device automatically bypasses those AT commands to the phone thus eliminating

- The need for two serial-port hardware on the MCU side. and
- A complex circuit for switching among the three modules: MCU, TNS010i, and GPRS.

Features

- Support basic protocols including TCP/IP, PPP, DNS ,HTTP,SMTP,POP3 and TCP/IP socket.
- Easy interface to GPRS phone or Modem.
- Input commands length as long as 1,000 bytes.
- No need for external RAM or ROM.
- Minimal components. Requires only one 18.432 MHz Xtal, and 3 Capacitors .
- 19,200 BPS Command communicates with micro controller (MCU)
- Information exchanges rate with GPRS is variable from 1,200 BPS to 57,600 BPS
- low power consumption
- 44-pin PLCC and LQFP package

The Connection Diagram

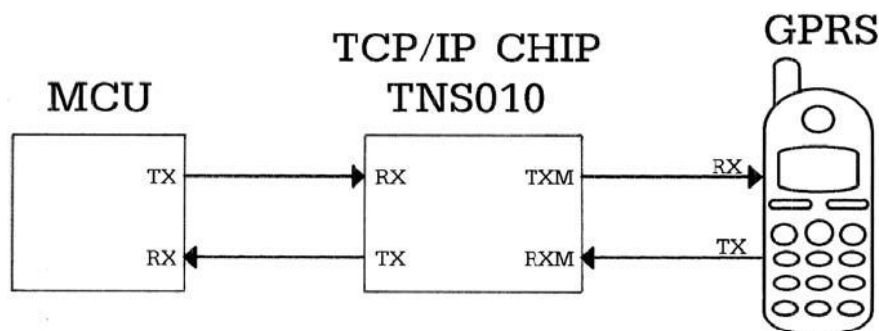

Electrical Characteristics

Symbol	Description	Min	Type	Max	Unit
VIL	Input Low Voltage	-0.5		0.9	V.
VIH	Input High Voltage	1.9		5.5	V.
VIH_	Input High Voltage XTAL1,RST	3.5		5.5	V.
Icc	Power supply current			60	mA
Vcc	Power supply voltage	4.75		5.25	V.

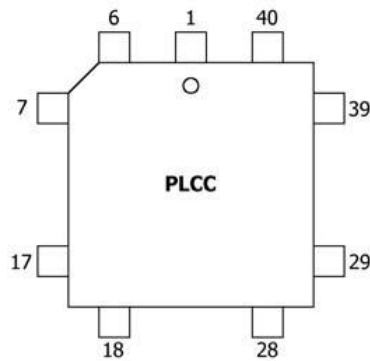
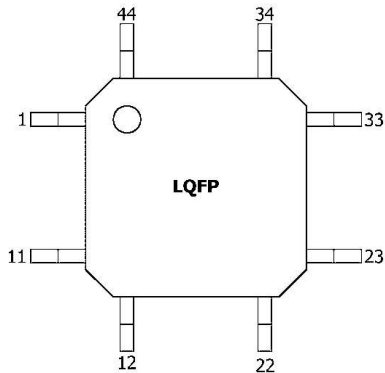

Pin Description

Symbol	PLCC	LQFP	In/Out	Name and Function
Vcc	44,35	38,29	I	Power Supply : power supply voltage for operation
Gnd	22	16	I	Ground : 0 V. reference
XTAL1	21	15	I	Crystal 1: 18.432 MHz. Input oscillator amplifier.
XTAL2	20	14	O	Crystal 2: 18.432 MHz. Output oscillator amplifier.
GPRS/modem	18	12	I	GPRS / Land line modem time out select
CD	2	40	I	Carrier detect
DTR	3	41	O	Data terminal ready
DSR	4	42	I	Data set ready
RTS	5	43	O	Request to send
CTS	6	44	I	Clear to send
RST	10	4	I	Reset : hold high at least 0.22 mS
TxM	13	7	O	Transmit to modem/GPRS phone
RxM	11	5	I	Receive from modem/GPRS phone
Tx	15	9	O	Transmit to controller
Rx	14	8	I	Receive from controller
LED-Connect	9	3	O	LED status shows connected to net
LED-Data trans	19	13	O	LED status shows data transferring

TCP/IP Software Specifications

Maximum at+i command length (include at+i itself)	1000 bytes
Maximum TCP segment size	512 bytes
Serial RX buffer length (Ring buffer)	2,500 bytes
Serial TX buffer length	1,000 bytes
PAP	Support
CHAP	Not support
DNS	Support
HTTP	Support
FTP	Not support
SMTP	Support
POP3	Support
TCP/IP socket	Support

Typical testing circuit

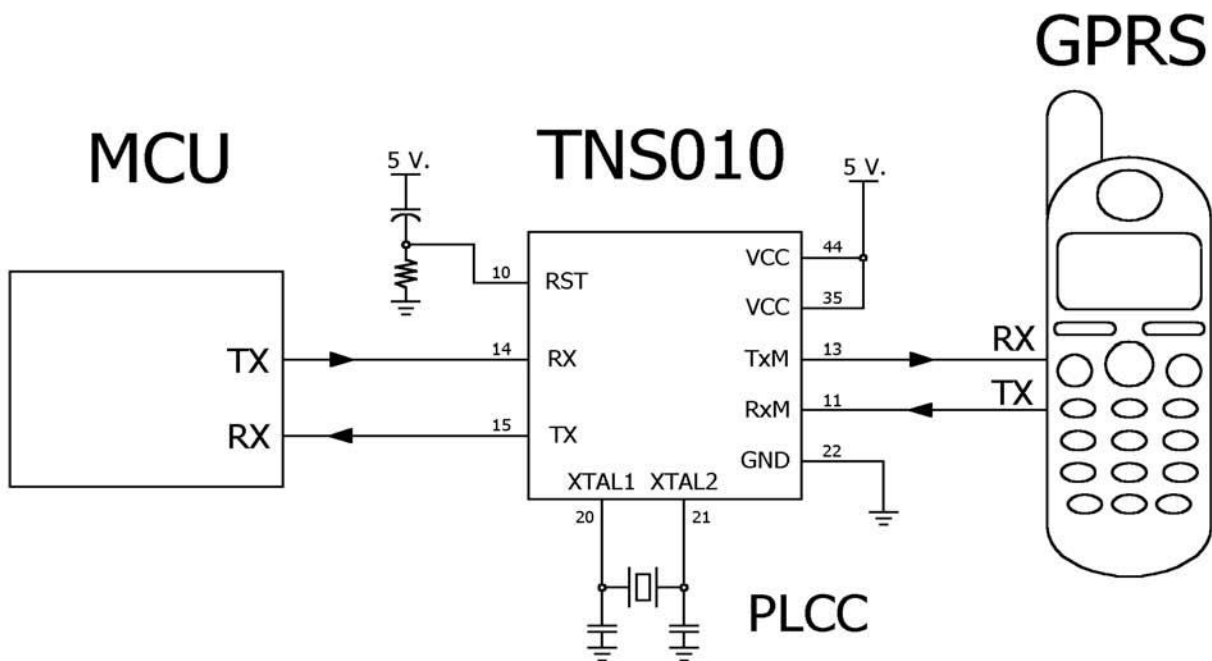

Summary of Commands

- 19,200 BPS command baud rate (MCU (controller) TCP/IP Chip) N-8-1
- 1,200-57,600 BPS GPRS/modem baud rate. (TCP/IP Chip GPRS/Modem) N-8-1
- Dark color are main commands and the **Gray color** are Option commands
- <CR> = Carriage Return Code = 13 or in hex format = 0x0d

Chip test

```
Command:  at+i<CR>
```

Response: +I_OK

Open a PPP connection

```
Command:  at+iopen<CR>
```

Response:

- Success +I_OK

- Not success

+I_ERROR 1 PPP_NOT_ESTABLISH (*can't connect to PPP server*)

+I_ERROR 3 DIAL_NOT_SET (*no dial number set up*)

+I_ERROR 4 MODEM_NOT_RESPONSE (*no modem response*)

+I_ERROR 7 PASSWORD_NOT_GOOD (*invalid password*)

Close a PPP connection

```
Command:  at+iclose<CR>
```

Response:

- Success +I_OK

- Not success

+I_ERROR 4 MODEM_NOT_RESPONSE (*can't disconnect modem*)

Display a current assigned IP address

```
Command:  at+iip<CR>
```

Response: CLIENT_IP=x.x.x.x
SERVER_IP=x.x.x.x
+I_OK

Set up a dialing number

Command: at+isetd= <ISP dialing number> <CR>

Response: +I_OK

Example: at+isetd=*99***1#<CR>
+I_OK

Display a dialing number

Command: at+isetd=?<CR>

Response: <DIAL NUMBER>
+I_OK

Example: at+isetd=?<CR>
*99***1#
+I_OK

Set up DNS server's IP address (in case of ISP does not assign DNS automatically)

Command: at+isetdns= <ip address><CR>

Response: +I_OK

Example: at+isetdns=203.155.33.1<CR>
+I_OK

Display DNS server's IP address

Command: at+isetdns=?<CR>

Response: <DNS SERVER IP ADDRESS>
+I_OK

Example: at+isetdns=? <CR>
203.155.33.1
+I_OK

Set up PPP user name

```
Command:   at+isetuser=<username><CR>
```

Response: +I_OK

Example: at+isetuser=David<CR>
 +I_OK

Display PPP user name

```
Command:   at+isetuser=?<CR>
```

Response: <USER NAME>
 +I_OK

Example: at+isetuser=? <CR>
 David
 +I_OK

Set up PPP password

```
Command:   at+isetpass=<password><CR>
```

Response: +I_OK

Example: at+isetpass=David password<CR>
 +I_OK

Display PPP password

```
Command:   at+isetpass=?<CR>
```

Response: <PASSWORD>
 +I_OK

Example: at+isetpass=?<CR>
 David password
 +I_OK

HTTP Request

```
Command:at+ihttp://<url>[<path>][:<port>][<space></h></l></d>]<CR>
```

Response:

```
- Success      +I_OK
                <WEB PAGE CONTENT.....
                .....
                .....
                .....>

- Not success  +I_ERROR 2 DNS_IP_NOT_SET
                (If call url domain name instead of IP address
                 Have to initial set a DNS IP address by at+isetdns command )
                +I_ERROR 5 TCP_TIMEOUT ( server is busy )
                +I_ERROR 0 PPP_CLOSED
                ( PPP is not established yet, must open with at+iopen )
```

Note:

1. /h = display all **header** field.
2. /l = display only **length** field
3. /d = display only **date** field
4. default port number is 80

```
Example: at+ihttp://www.google.com /l<CR>
          +I_OK
          Content-Length:2998
          <html><head><meta http-equiv="content-type"
          content="text/html; charset=windows-
          874"><title>Google</title><style><!--
          body,td,a,p,.h{font-family:;}
          .h{font-size: 20px;}
          .q{text-decoration:none; color:#0000cc;}
          .....
          .....
          </html>
```

```
Example: at+ihttp://www.myserver.com:123/doc.htm /d/l<CR>
          +I_OK
          Date: Mon, 29 Dec 2003 12:29:09 GMT
          Content-Length: 3203
          <HTML>.....
          .....
          .....
          </HTML>
```

How to request the next HTTP ?

After successfully retrieving the first web page, the successive request needs no further initial set-up commands. Just send same command again.

```
Command: at+ihttp://<url>[<path>][:<port>][<space></h></l></d>]<CR>
```

In case a connection is broken

1. Close the existing connection first with

```
Command: at+iclose<CR>
```

2. Then re-open PPP connection with

```
Command: at+iopen<CR>
```

3. Followed by requesting a web page

```
Command: at+ihttp://<url>[<path>][:<port>][<space></h></l></d>]<CR>
```

TCP/IP SOCKET

1.OPEN TCP/IP SOCKET

Command: at+isockopen=<url>:<port><CR>

Response: +I_OK
<RESPONSE/NONE>
Note: <port> is required , no default value

Example: at+sockopen=mail.server.com:25<CR>
+I_OK
220 SMTP Service ready

2.SEND DATA ON TCP/IP SOCKET

Command: at+isock=<data><CR>

Response: +I_OK
<RESPONSE/NONE>

Example: at+sock= HELO\r\n<CR>
+I_OK
250 HELLO <CR>

3.CLOSE TCP/IP SOCKET

Command: at+isockclose<CR>

Response: +I_OK

EMAIL SEND/RECEIVE (SMTP & POP3)

1.OPEN -> SEND -> CLOSE Mail

Command:

```
at+ismtpsend=<mailserver>[:<port>],<from>,<to>,<subject>,<data><CR>
```

Response: **+I_OK**
 or
 +I+ERROR 10 MAIL_ERROR

Note:

<port> default value is 25.

Example:

```
at+ismtpsend=mail.server.com,sender@aaa.com,  
recv@bbb.com,My subject,Hello how are you?<CR>  
+I_OK
```

2.READ EMAIL(POP3)

2.1 OPEN -> List all mails and show mail's number in Inbox

Command:

```
at+ipop3open=<mailserver>[:<port>],<user_name>,<password><CR>
```

Response: **< mail number list >**
 +I_OK

 or +I+ERROR 10 MAIL_ERROR

Note:

<port> default value is 110.

Example: at+ipop3open=pop3.server.com,david,1234<CR>
 1,2,3,4,5
 +I_OK

2.2 READ EMAIL

Command:

```
at+ipop3read=<mail_number><CR>
```

Response: **< mail content >**
 +I_OK

 or +I+ERROR 10 MAIL_ERROR

Example:

```
at+ipop3read=4<CR>  
From: sender@aaa.com  
Subject: Test
```

Hello , How are you?
+I_OK

2.3 CHECK MAIL

Command:	at+ipop3check<CR>
----------	-------------------

Response: < mail number list >
+I_OK
or
+I+ERROR 10 MAIL_ERROR

Example:

```
at+ipop3check<CR>
1,2,3,4,5
+I_OK
```

2.4 DELETE MAIL

Command:	at+ipop3delete=<mail number><CR>
----------	----------------------------------

Response: < mail number >
+I_OK
or
+I+ERROR 10 MAIL_ERROR

Note: mail number

"all" = delete all messages
num1, num2, num3 = delete specific messages
num1-num2 = delete range of messages

Example:

```
at+ipop3delete=1,2,6<CR>
3,4,5 //display undelete message
+I_OK
```

```
at+ipop3delete=all<CR>
```

```
+I_OK
```

```
at+ipop3delete=4-10<CR>
1,2,3 //display undelete message
+I_OK
```

2.5 CLOSE READING EMAIL SERVER

Command:	at+ipop3close<CR>
----------	-------------------

Response: +I_OK
or
+I+ERROR 10 MAIL_ERROR

Read firmware version of TNS010i

```
Command: at+iver<CR>
```

Response: VERx.xx
+I_OK

Example: at+iver <CR>
VER0.07
+I_OK

Bypass to modem's AT commands mode

1st Step :

type +++ and <cr> to make it is ready for modem's AT commands mode

```
Command: +++<CR>
```

Response: +I_OK

2nd step :

Case1 : if modem is not connected to internet
Type **at<cr>** to initiate and enter modem's commands mode
OK response from modem

Case2 : if modem is connected to internet
Type +++ and wait for 2-3 sec. and then type
at<cr> to initiate and enter modem's commands mode
OK response from modem

From this state you can communicate to modem with it's AT Commands

To quit from modem's AT commands mode and enter TNS010i commands mode

Case1 : if modem is not connected to internet
Type **at+i<cr>** to enter TNS010i's commands mode
+I_OK response from TNS010i

Case2 : if modem is connected to internet
Type **ato** to enter modem's internet connecting state
CONNECT response from modem
and then type

at+i<cr> to enter TNS010i's commands mode
+I_OK the response from TNS010i

Turn on DEBUG mode

Debug mode on = print out some more information when chip is in Processing.

Command: at+idebug1<CR>

Response: **+I_OK**

Turn off DEBUG mode

Command: at+idebug0<CR>

Response: **+I_OK**

Set up TCP time out

Command: at+isettcpto=<TCP time out value ><CR>

Response: **+I_OK**

tcpto=8<CR> (1-255 Sec.)

Example: at+iset
+I_OK

Display TCP time out value

Command: at+isettcpto=?<CR>

Response: **<Time-out value>**
+I_OK

Example: at+isettcpto=?<CR>
8
+I_OK

Set up DNS time out

Command: at+isetdnsto=<DNS time out value ><CR>

Response: **+I_OK**

Example: at+isetdnsto=8<CR> (1-255 Sec.)

+I_OK

Display DNS time out value

Command: `at+isetdnsto=?<CR>`

Response: `<Time-out value>`
`+I_OK`

Example: `at+isetdnsto=?<CR>`
`8`
`+I_OK`

Set up Modem time out

Command: `at+isetmodemto=<time out value ><CR>`

Response: `+I_OK`

Example: `at+isetmodemto=8<CR>` (1-255 Sec.)
`+I_OK`

Display Modem time out

Command: `at+isetmodemto=?<CR>`

Response: `<Time-out value>`
`+I_OK`

Example: `at+isetmodemto=?<CR>`
`8`
`+I_OK`

Detect and automatic set modem interfacing baudrate.

Command: `at+idetect<CR>`

Response: `xxxx`
`+I_OK`

Example: `at+idetect<CR>`
`9600`
`+I_OK`

Manual set up GPRS/modem interfacing baud rate

```
Command: at+isetbaud=<baud rate><CR>
```

Response: **+I_OK**

Available Baud rate list:

```
57600 BPS.(default)
38400
19200
9600
4800
2400
1200
```

Example: at+isetbaud=9600<CR>
+I_OK

Display GPRS/modem interfacing baud rate

```
Command: at+isetbaud=?<CR>
```

Response: **<baud rate value>**
+I_OK

Example: at+isetbaud=?<CR>
9600
+I_OK

Data counter

Check amount of total data transfer

```
Command: at+icount=?<CR>
```

Response: **<data transfer counter>** Bytes
+I_OK

Example: at+icount=?
1371
+I_OK

Reset data transfer counter

```
Command: at+icount=0<CR>
```

Response: +I_OK

```
Example: at+icount=0<CR>
         +I_OK
```

note: the data counter command available only in ver 4.03 up

Modem's flow Control

Setting Modem's data flow control

```
Command: at+icomlctrl=hard/none<CR>
```

Response: +I_OK

```
Example: at+icomlctrl=none<CR>
         +I_OK
```

Read Modem's flow control status

```
Command: at+icomlctrl=?<CR>
```

Response: HARD/NONE
+I_OK

```
Example: at+icomlctrl=?<CR>
         NONE
         +I_OK
```

note : default = none

Dev-010i-B's modem connection is null modem type

Power Down mode (for energy saving)

Put TNS010i into power down mode

```
Command: at+ipwrdown<CR>
```

Response: +I_OK

**** In power down mode TNS010i will reduce the consume current to 25 uA.
** return to active mode by sending a reset pulse.**

GPRS phone / Modem Time Out

When power on reset. TNS010i will load a modem time out default value according to the logic level below.

GPRS sel. = high(or no connect)
LAND LINE MODEM sel. = low (connect to GND.)

Note:

GPRS modem time out default value = 10 Sec.

Land line modem time out default value = 60 Sec.

you can change these default value by issue
at+isetmodemto=xxx

Error message response

```
+I_ERROR 0 PPP_CLOSED
+I_ERROR 1 PPP_NOT_ESTABLISH
+I_ERROR 2 DNS_IP_NOT_SET
+I_ERROR 3 DIAL_NOT_SET
+I_ERROR 4 MODEM_NOT_RESPONSE
+I_ERROR 5 TCP_TIME_OUT
+I_ERROR 6 DNS_TIME_OUT
+I_ERROR 7 PASSWORD_NOT_GOOD
+I_ERROR 8 CONNECT_LOST
```

Development board DEV-010i-B wiring guide

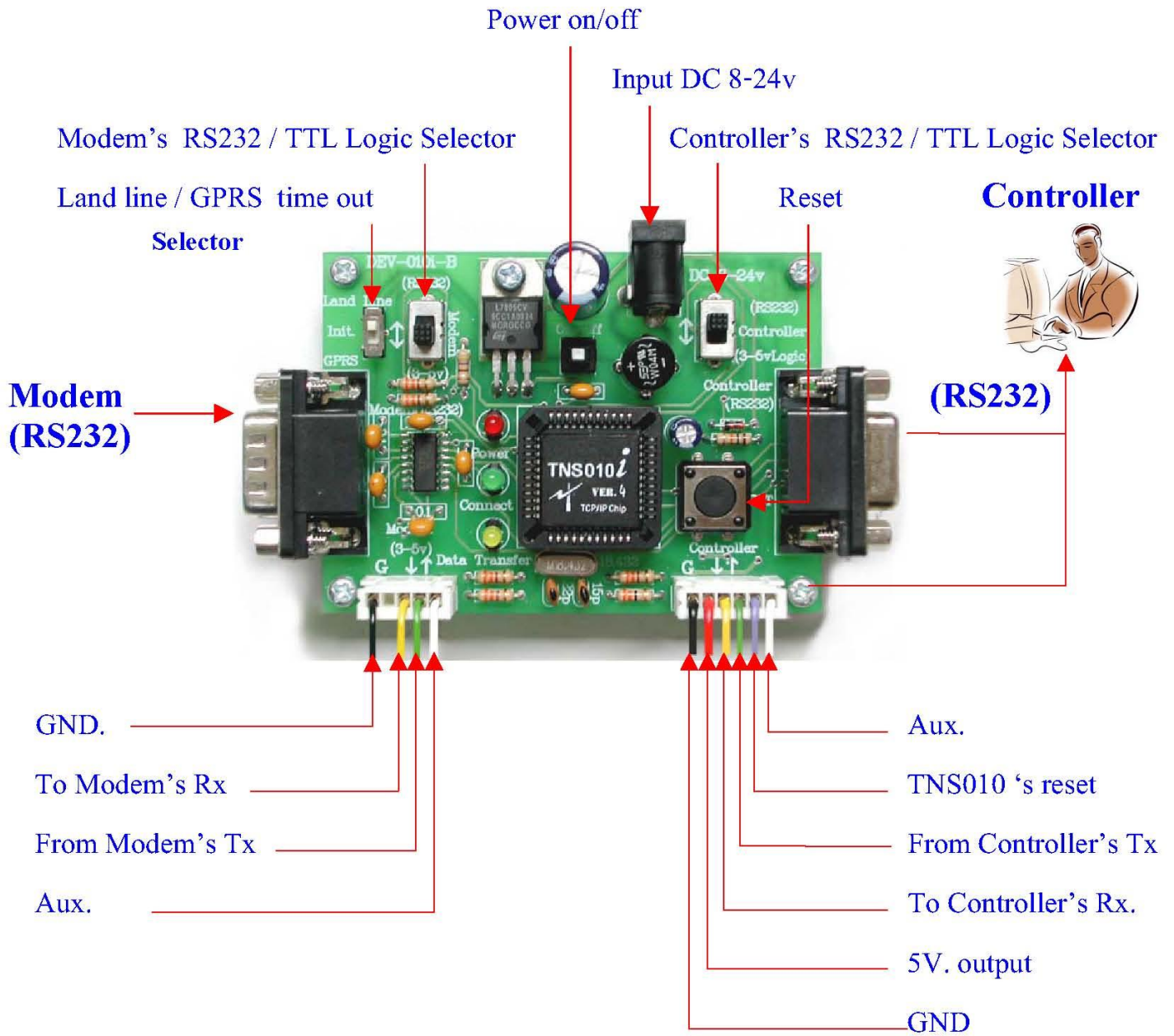

DEV-010i-B schematic

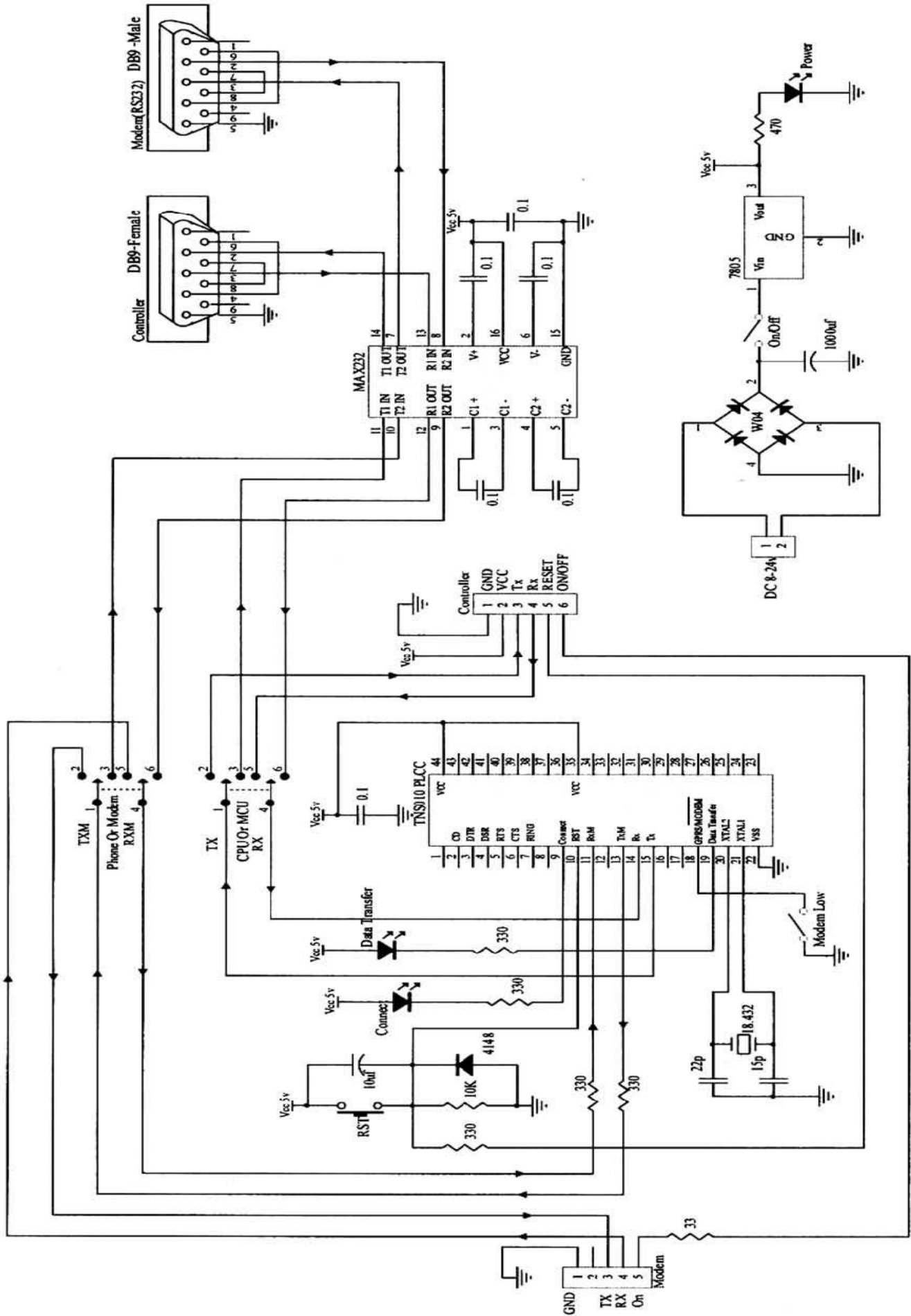

Some old GPRS phone data link details

Siemens S45 connector's pin out

1. Gnd
2. -
3. Charge
4. -
5. Tx (out from phone)
6. Rx (into phone)

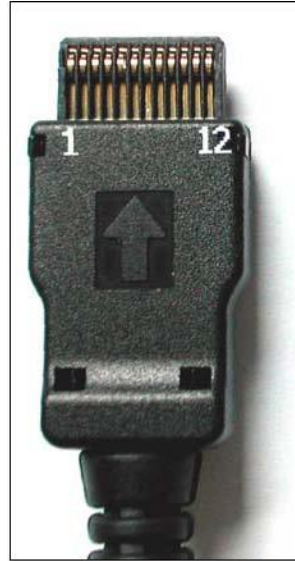

Siemens C55

2. Gnd.
3. Tx
4. Rx

Ericsson T65/68/200 connector's pin out

1. Charge
2. Gnd
3. -
4. Gnd
5. -
6. -
7. TX (out from phone)
8. RX (into phone)
9. Power ON (TRIG LOW) **** ONLY ERICSSON T65/T68 ****



Quick Start Guide

TNS010i works well with any GPRS phone or GPRS modem module.
Such as

- Ericsson T65/T68/T200
- Siemens S45/ C55
- Wavecom Integra-GPRS (GPRS module)
- Etc.

** Recommendation for Wavecom integra **

1. Set GPRS modem to baudrate = 57600
by send AT+IPR=57600 and
2. Save this setting value in it's EEPROM
by send AT&W
3. Send AT+WOPEN=0

Following is the sample how to start TNS010i with Ericsson/Siemens phone

Testing phone parameters

1. Ensure that the GPRS phone have been activated and tested to verify the connection.

In case of Ericsson, and Siemens C55 you need to purchase a [data link cable \(built in RS232 IC.\)](#) available from it's dealer.

2. Set the phone parameter according to the recommendations from your GPRS service provider. You may consult a sample web page of how to set at

<http://www.mobilelife.co.th/mobilelife/t/customertools/mobilesetting/manual/gprs/index.htm>

or from your local GRPS 'provider web site

Note that the parameters may be vary from country to another, and from one provider to another.

3. Add "New Hardware" GPRS phone/modem to your PC (you will need GPRS phone driver that should come with the phone).

4. Add "New Internet Connection". Choose your GPRS phone as a modem

5. Connect the GPRS phone via [its data link cable \(built in RS232 IC\)](#) and connect to Internet by choosing a GPRS modem.

6. Try surfing the web page via your GPRS phone

If you are successful in surfing the web page with the GPRS phone then proceed to the next step.

Testing the TNS010i chip on Window's Hyperterminal program

As an alternative to reduce the overall manufacturing cost and the package size, a data link cable with no RS232IC in its cable can be used given that there is the same logic voltage level to and from the MCU and the GPRS phone.

7. Close all the Internet connections in PC including any web browser. Then remove the data link cable.

8. Open Hyper terminal program in the Windows (N-8-1 19,200 BPS)

9. Connect the GPRS phone to the a new development board 's [data link cable\(no RS232 IC\)](#) and turn the power on.

10. As soon as the development board is powered up, the "I_READY" sign should appear on the Hyper terminal screen.

11. Type the following sequence of commands in its order

→ at+i <ENTER> /* TCP/IP chip response testing */
← +I_OK

→ at+idetect<ENTER> /* detect/set modem baudrate */
← 57600 /* modem's baud rate */
← +I_OK

Skip the following gray colour steps if your GPRS modem's parameter was set correctly

→ +++<ENTER> /* quit TNS010's commands mode */
← +I_OK

wait 0-3 Sec. (depend on brand /model of modem)

→ at<ENTER> /* Initiate modem's commands mode */
← OK

→ at+cgdcont=xxx /* xxx = GPRS parameter setting Example = 1,"ip","internet" */
← OK

→ at+i <ENTER> /* Enter TNS010i's commands mode */
← +I_OK

at+isetd=xxx /* xxx = ISP dial number Example = *99***1# */
+I_OK

at+iopen /* connect to ISP and open the TCP/IP socket */
+I_OK

at+ihttp://xxx /* xxx=url IP / url domain name */

Example

at+ihttp://203.130.155.66/test.php?content1=123&content2=345 </l , /d , /h>
+I_OK

(suffix (/l,/d,/h) is for showing data's length / present date / or full header /or nothing (default))

<html><html> /* HTTP response data*/

Products Distributor: <http://www.es.co.th>
Products Website : <http://www.tcpipchip.com>
Technical Support and Sales: tstns@gmail.com

